

Prizelawn® CD36C

COMMERCIAL DROP SPREADER

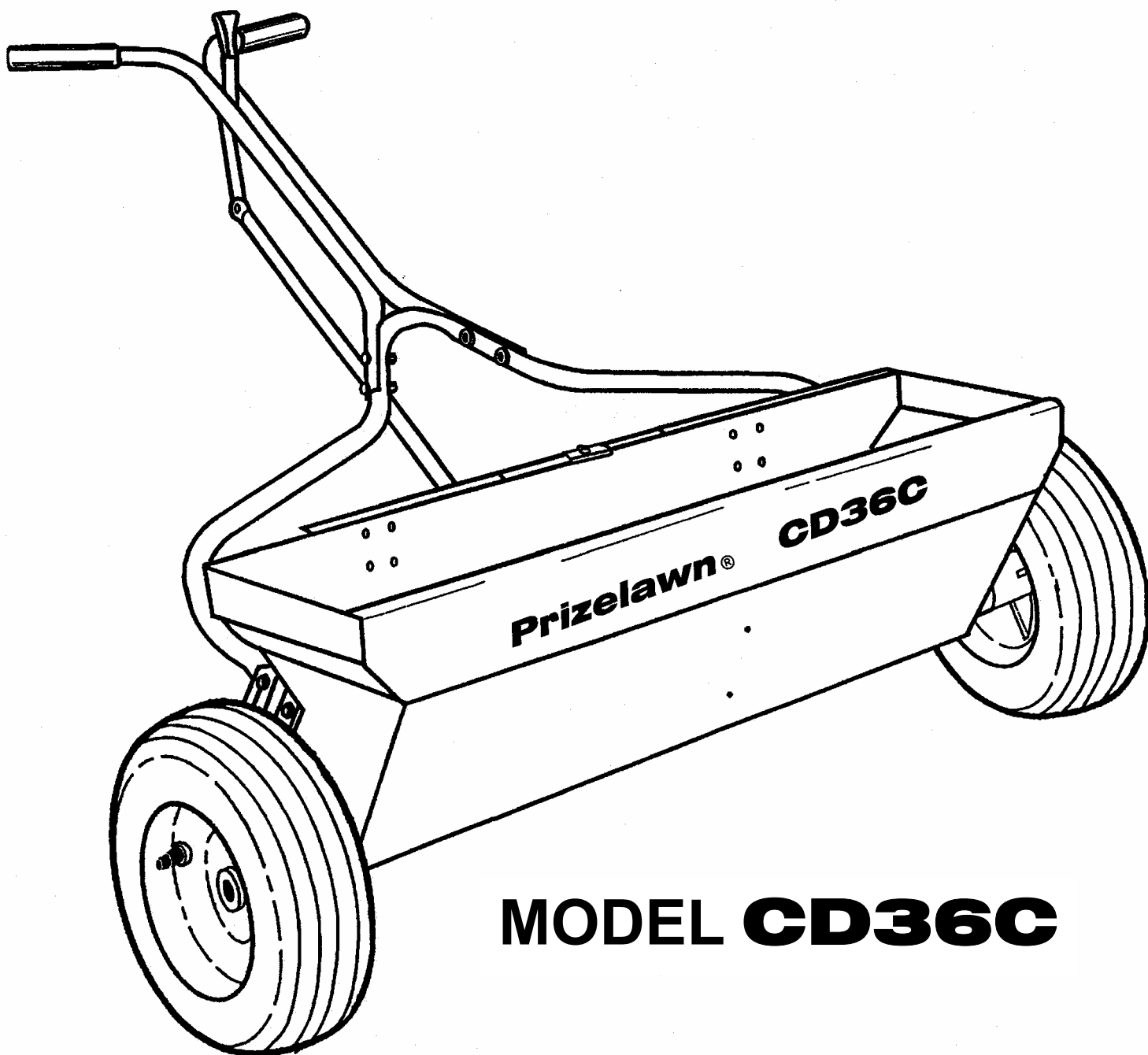

MODEL CD36C

OWNER'S MANUAL

Assembly Instructions

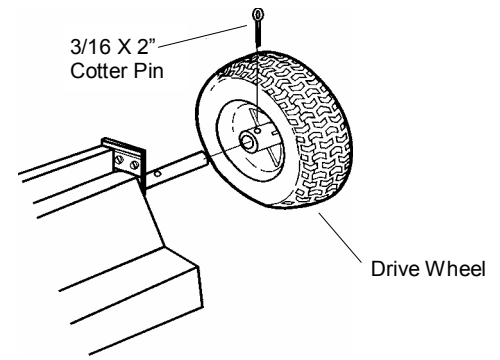
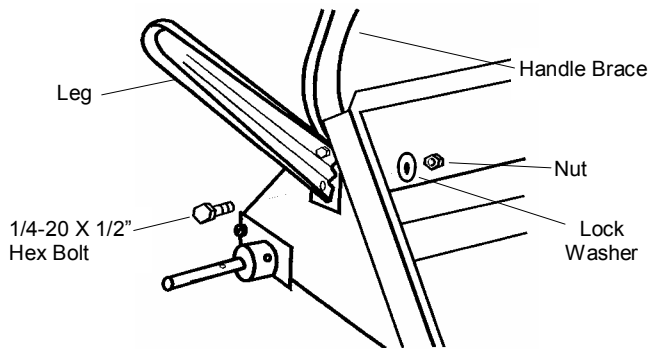

1. Remove spreader and components from carton. Place Hopper on it's front panel, insert two (2) 1/4-20 X 1/2" Hex Head Bolts through the Leg, flattened end of Handle Brace, and holes in Hopper as shown. Install Lockwashers and Nuts but do not tighten. Repeat on opposite side.

2. Slide Wheels onto each end of Axle with the longer portion of the Wheel facing the Hopper. Secure Wheels with 3/16 dia. x 2" Cotter Pins.

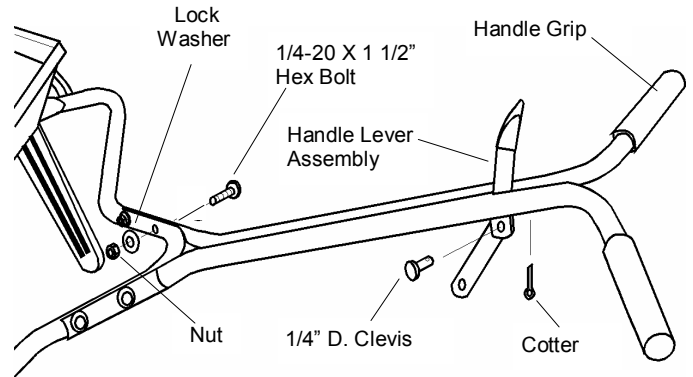
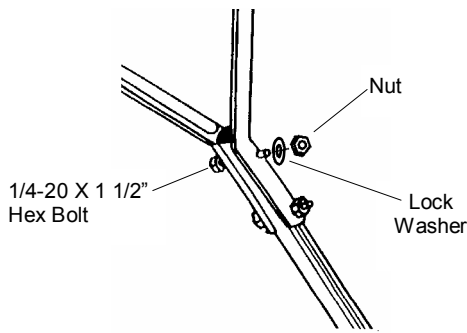

3. Install Control Tube between the Control Tube Braces and secure with (2) 1/4-20 X 1 1/2" Hex Bolts, Lockwashers, and nuts.

4. Stand spreader upright on Wheels. Attach Upper Handle assembly to Handle Brace (make sure Handle is positioned as shown) using (4) 1/4-20 X 1 1/2" Hex Bolts, (4) Lock Washers, and (4) Nuts. Tighten securely. Install Handle Grips onto Upper Handle. Slide Handle Lever assembly between Handle Brackets and secure with 1/4 dia, Clevis and Cotter Pin. Make sure Lever pivots freely.

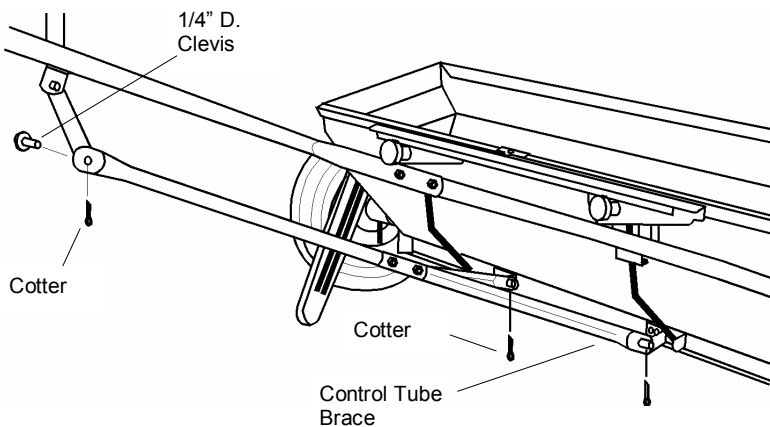

5. Slide the ends of the Control Tube Braces over the Studs on the Shutoff Bar Brackets, secure with Cotter Pins. Attached opposite end of Control Tube to the Handle Lever using 1/4 dia. Clevis and Cotter Pin. Make sure Handle Lever operates freely. Tighten all Nuts left loose in step #1.

6. To check spreader for completed shutoff, pull the Handle Lever back to the "OFF" position. Turn spreader over to see if the Shutoff Bar completely covers the holes in the bottom of the Hopper. If not, stand the spreader upright on Wheels push the Handle Lever forward to the "ON" position. Loosen the Bolts in the Hopper holding the Handle Brace. Push down on the Handle Brace and the front of the Hopper. Retighten Bolts and check the shutoff.

Operation

1. Before filling Hopper, make sure spreader Handle Lever is in the "OFF" position. Always fill spreader on walk or drive, not on the lawn.

2. Loosen Rate Control Knobs and move the Tie Bar to setting recommended for the product applied. If PrizeLAWN settings are not available, use Scotts® drop spreader settings. If setting is not known, refer to "DETERMINING APPLICATION RATES" section of this book. Retighten knobs after setting is made.

3. Always push spreader, do not pull. Start spreader in motion and as it passes over the area to be treated, push Handle Lever to the "ON" position. Close Handle Lever at the end of each pass.

4. Operate spreader at 3 MPH pace. (33.3 feet in 7.5 seconds)

5. Apply two header strips at each end of area to be treated and then proceed lengthwise between the header strips. Be sure to overlap the wheel tracks slightly to prevent streaking.

6. When applying lime, do not use limestone that is so finely ground that it will pack inside the Hopper, or use hard, abrasive particles which will damage the spreader. Use only compacted, free flowing, non-abrasive lime products.

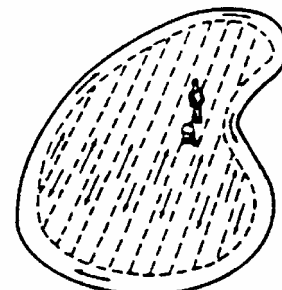
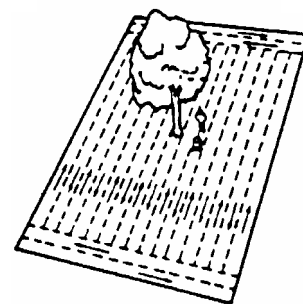

Determining Application Rates For Drop Spreaders

The following procedure provides a means of accurately determining drop spreader settings when settings do not appear on the package, or to "fine tune" the manufacturer's recommend settings. Spreader rates can vary due to walking speed, condition of turf, humidity, physical characteristics of the product being applied, or condition of the spreader. It is good practice to double check settings using the following method:

PROCEDURE	EXAMPLE
1. The manufacturer will recommend coverages on the product package. Generally, it is stated as applying a certain number of pounds of product per 1,000 square feet.	The contents of this package (25 lbs.) covers 2,000 square feet.
2. Determine the amount of material in pounds to cover 100 square feet. Add two zeros to weight of bag and divide that by the square foot coverage.	2,500 divided by 2,000 square feet = 1.25 lbs.
3. To change the decimal portion of answer in step #2 to ounces, multiply decimal portion by 16.	0.25 x 16 oz. = 4 oz. Total weight = 1 lb.- 4 oz.

4. On a clean walk of driveway, measure out 33.3 feet- the distance required to cover 100 square feet.

5. Add a measured amount of product to the spreader- 2 to 3 times the recommended rate. Operate spreader at a brisk walking speed (3 mph of 33.3 feet in 5. sec.) over the measured distance. Empty the spreader and weigh the amount left. Compare with the beginning amount; the difference is the amount applied. Adjust the setting up or down to achieve the correct application rate.

Maintenance

- Never store unused material in spreader. Return unused product to its original container.
- Set Rate Slide on the highest number, open spreader and spin Wheels to remove excess material.
- Wash out Hopper thoroughly after each use to remove material clinging to surfaces. Pay close attention to area between the Shutoff Bar and Hopper. Allow spreader to completely dry.
- Oil bottom of Hopper, Control Housing Spring and Agitators at the Center Bearing. Lubricate Axle Bearings with grease. Store spreader in open position.

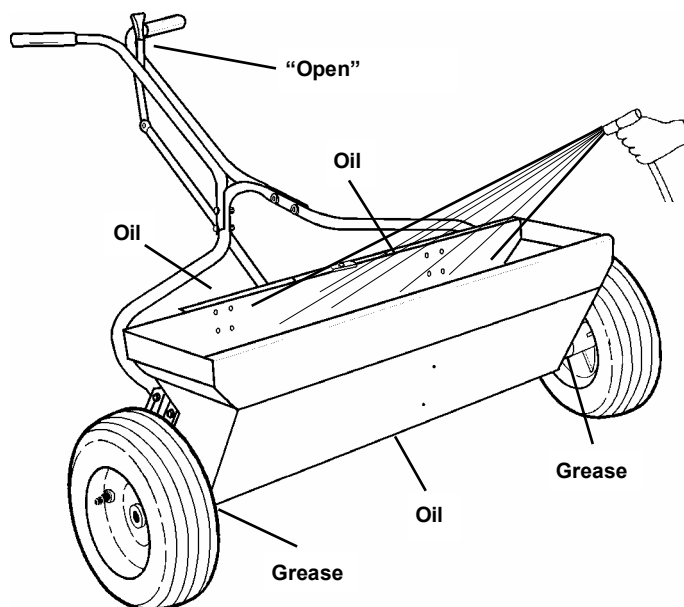

Parts List for Model CD36C

PART OF OUR SERVICE IS PROVIDING REPLACEMENT PARTS. Parts may be obtained through your local distributor. Be sure to give:

1. SPREADER MODEL NUMBER
2. SPREADER NAME
3. PART NUMBER
4. NAME OF PART AS SHOWN

IF YOUR LOCAL DISTRIBUTOR CANNOT SUPPLY PARTS, CONTACT:

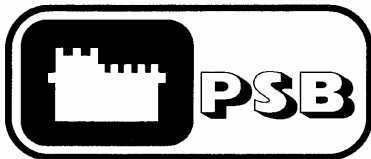

PSB Company

555 West Goodale Street P.O. Box 1089

Columbus, Ohio 43216-1089

614-228-5781 EXT. 2655

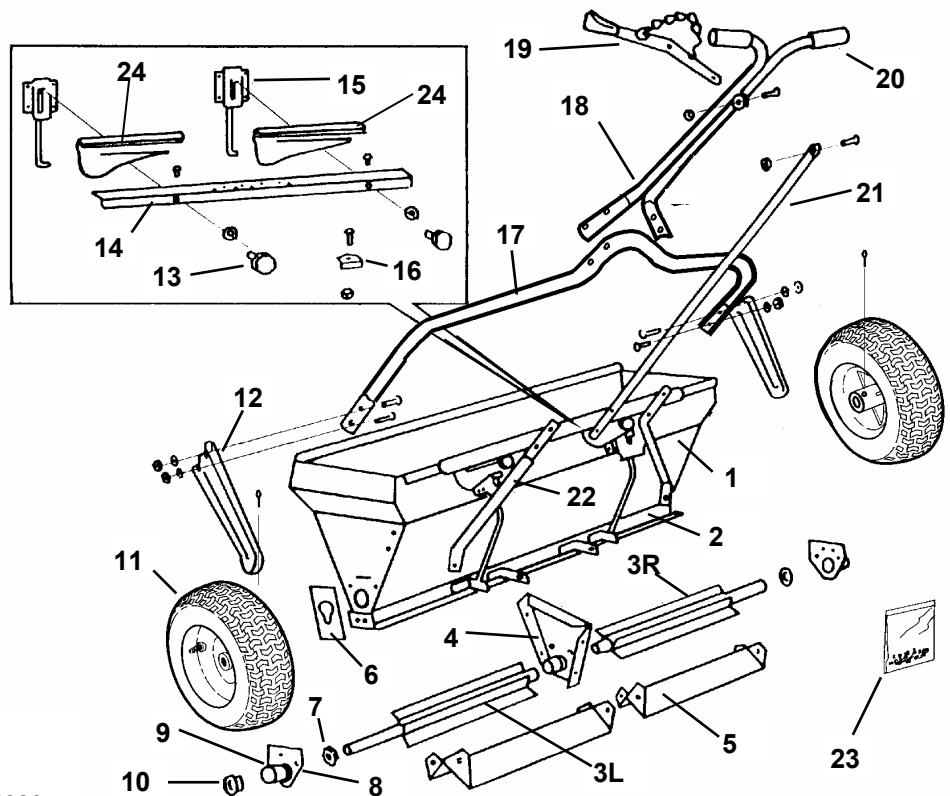

PARTS LIST

WARRANTY

PSB warrants to Purchaser the following:

1. Product will be free of defects in materials and workmanship for a period of one year from date of purchase.
2. PSB will decide in its reasonable discretion if the part(s)/unit is defective.
3. The spreader or part(s) will be shipped to PSB at the customer expense with a written description of defect to the attention of PSB WARRANTY DEPARTMENT.
4. If the spreader is used for commercial rental the Limited Warranty shall be limited to a period of 90 days.
6. All Unit and part replacement will be performed at the reasonable discretion of PSB.
7. Labor charges are not covered and the unit need not be returned to the dealer for warranty service.
8. Proof of purchase must be supplied to PSB.

PSB's sole obligation under this warranty is limited to repairing or replacing the defective part. Upon replacement of any Product or Product part, the replaced item shall become the property of PSB. If PSB determines that the Product covered by this warranty requires service, PSB shall prepay return shipping charges from PSB. In all other instances, such charges shall be paid by Purchaser. Except for loss or damage caused by PSB's negligence, Purchaser relieves PSB of responsibility for all risks of loss or damage to the Product and its parts during the period the products are in transit to and from PSB.

This warranty does not extend to any Product or parts thereof that have been allowed to corrode, subjected to misuse, neglect, accident, or modification by anyone other than PSB or that have been affixed to any nonstandard accessory attachment or that have been used, stored, installed, maintained or operated in violation of PSB's instructions or standard industry practice. No agent, employee or representative of PSB has any authority to bind PSB to any affirmation, representation or warranty concerning the Product and any affirmation, representation or warranty made by any agent, employee or representative shall not be enforceable by Purchaser.

THIS WARRANTY EXTENDS ONLY TO THE ORIGINAL PURCHASER AND IS EXPRESSLY IN LIEU OF ANY OTHER EXPRESS OR IMPLIED WARRANTIES, INCLUDING WITHOUT LIMITATION ANY IMPLIED WARRANTY OR MERCHANTABILITY OR FITNESS OR INTENDED USE FOR A PARTICULAR PURPOSE AND OF ANY OTHER OBLIGATION ON THE PART OF PSB.

PSB SHALL NOT BE LIABLE FOR ANY INCIDENTAL, SPECIAL OR CONSEQUENTIAL LOSS, DAMAGE OR EXPENSE DIRECTLY OR INDIRECTLY ARISING FROM THE USE OF ANY OF THE PRODUCT INCLUDING, BUT NOT LIMITED TO, DAMAGE OR LOSS OF OTHER PROPERTY OR EQUIPMENT, LOSS OF PROFITS OR REVENUE, COST OF CAPITAL, COST OF PURCHASED OR REPLACEMENT GOODS, OR CLAIMS OF CUSTOMERS OF PURCHASER.

ITEM	PART #	DESCRIPTION
1	14211-1	HOPPER ASSEMBLY
2	14414-2	SHUTOFF BAR ASSEMBLY*
3 RH.	14643-1	AGITATOR/AXLE ASSEMBLY-LH. *
3 LH.	14644-1	AGITATOR/AXLE ASSEMBLY-RH.*
4	14231	BEARING SUPPORT ASSEMBLY*
5	14235	AGITATOR BAFFLE* (2)
6	14227	END HANGER* (2)
7	14007	AXLE GREASE SEAL* (2)
8	14222-1	PLATE ASSEMBLY-BEARING END* (2)
9	90005	GREASE FITTING* (2)
10	14006	AXLE BEARING* (2)
11	15032	WHEEL & TIRE ASSEMBLY (2)
12	12714	LEG (2)
13	12704	RATE CONTROL KNOB* (2)
14	14237	TIE BAR*
15	14286	SPRING HOUSING ASSEMBLY* (2)
16	12708	POINTER*
17	15029-1	HANDLE BRACE
18	15046	UPPER HANDLE ASSEMBLY
19	14047	HANDLE LEVER ASSEMBLY W/ CHAIN
20	14870	HANDLE GRIP (2)
21	14415-1	CONTROL TUBE
22	14409	CONTROL TUBE BRACE (2)
23	15066	FASTENER PACKAGE
24	14236	RATE PLATE* (2)
—	15063	PARTS PACKAGE (NOT SHOWN)

*Parts included in hopper assembly © 2004 PSB COMPANY